

SAE Technical Standards Board Rules provide that: "This report is published by SAE to advance the state of technical and engineering sciences. The use of this report is entirely voluntary, and its applicability and suitability for any particular use, including any patent infringement arising therefrom, is the sole responsibility of the user." SAE reviews each technical report at least every five years at which time it may be reaffirmed, revised, or cancelled. SAE invites your written comments and suggestions.

AS24586

FEDERAL SUPPLY CLASS
5360

NOTICE

THIS DOCUMENT HAS BEEN TAKEN DIRECTLY FROM U.S. MILITARY SPECIFICATION MS24586, AMENDMENT 1 AND 2 AND CONTAINS ONLY MINOR EDITORIAL AND FORMAT CHANGES REQUIRED TO BRING IT INTO CONFORMANCE WITH THE PUBLISHING REQUIREMENTS OF SAE TECHNICAL STANDARDS. THE INITIAL RELEASE OF THIS DOCUMENT IS INTENDED TO REPLACE MS24586, AMENDMENT 1 AND 2. ANY PART NUMBERS ESTABLISHED BY THE ORIGINAL SPECIFICATION REMAIN UNCHANGED.

THE ORIGINAL MILITARY SPECIFICATION WAS ADOPTED AS AN SAE STANDARD UNDER THE PROVISIONS OF THE SAE TECHNICAL STANDARDS BOARD (TSB) RULES AND REGULATIONS (TSB 001) PERTAINING TO ACCELERATED ADOPTION OF GOVERNMENT SPECIFICATIONS AND STANDARDS. TSB RULES PROVIDE FOR (A) THE PUBLICATION OF PORTIONS OF UNREVISED GOVERNMENT SPECIFICATIONS AND STANDARDS WITHOUT CONSENSUS VOTING AT THE SAE COMMITTEE LEVEL, AND (B) THE USE OF THE EXISTING GOVERNMENT SPECIFICATION OR STANDARD FORMAT.

UNDER DEPARTMENT OF DEFENSE POLICIES AND PROCEDURES, ANY QUALIFICATION REQUIREMENTS AND ASSOCIATED QUALIFIED PRODUCTS LISTS ARE MANDATORY FOR DOD CONTRACTS. ANY REQUIREMENT RELATING TO QUALIFIED PRODUCTS LISTS (QPL'S) HAS NOT BEEN ADOPTED BY SAE AND IS NOT PART OF THIS SAE TECHNICAL DOCUMENT.

THIRD ANGLE PROJECTION

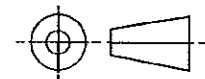

ISSUED 2001-10

PREPARED BY SAE COMMITTEE E-25

PROCUREMENT SPECIFICATION: MIL-S-13572



AEROSPACE STANDARD

SPRING, HELICAL, EXTENSION;
FOR LOADS BELOW 30 POUNDS

AS24586
SHEET 1 OF 10

AS24586

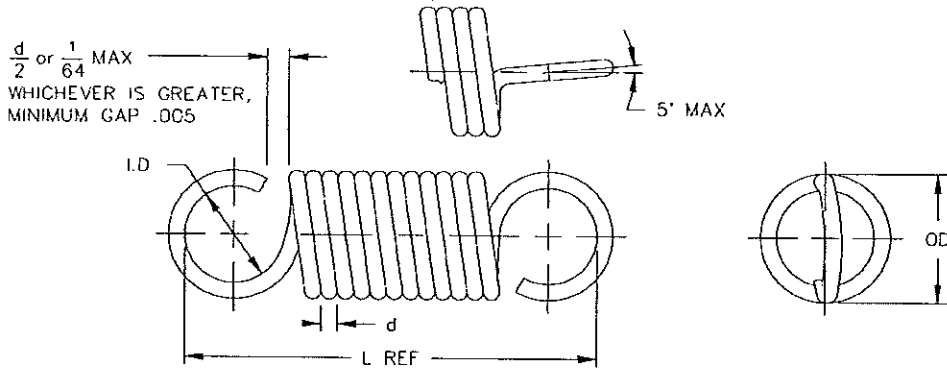

MATERIAL: WIRE, STEEL, MUSIC, IN ACCORDANCE WITH QQ-W-470. WIRE, STEEL, CORROSION-RESISTANT, IN ACCORDANCE WITH QQ-W-423, COMPOSITION FS302 OR FS304, SPRING TEMPER.

PROTECTIVE COATING: CADMIUM PLATING IN ACCORDANCE WITH QQ-P-416, TYPE II, CLASS 2.
ZINC COATING IN ACCORDANCE WITH ASTM B 633, TYPE II, Fe/Zn5.
PASSIVATION TREATMENT IN ACCORDANCE WITH QQ-P-35.

ENDS: Machine full hook. End hooks shall be parallel within 22°. Relative position of end hook openings is optional.

DIRECTION OF HELIX: Optional.

TOLERANCE: Outside diameter "O.D." .120 to .240 ± .005, .300 to .500 ± .008, .650 to 1.000 ± .015.
Wire diameter "d" in accordance with material specification.
Max extension "L₁" ± 10% of (L₁-L).
Spring rate "R" ± 10%.

DIMENSIONS: All dimensions are in inches unless otherwise specified.

PART NUMBER: The MS part number consists of the MS number, plus the dash number. Example: MS24586-1.

- NOTES:**
- (1) Active Coils "N", Initial Tension "T", and Deflection Per Coil "f", are for reference use only.
 - (2) MAX LOAD "P", SHALL BE ATTAINED WITHIN THE TOLERANCE OF EXTENSION "L₁". TO DETERMINE LOAD "P", RATE "R", OR INITIAL TENSION "T", FOR CORROSION-RESISTANT STEEL, MULTIPLY THE VALUE GIVEN IN TABLE II BY .833.
 - (3) Spring values shown are for music wire, and are based on a service life of 50,000 cycles at .50 stress range. For use under other operating conditions, multiply Max Extension (L₁-L) by the factor shown in Table I. (See Note (2)). P₁ = load at assembled height and P₂ = final load.
 - (4) To determine Load "P", at any extension other than "L₁", multiply the distance in inches that the spring will be extended from the Free Length "L", by the Spring Rate "R", and add the Initial Tension "T". (See note (2)).
 - (5) Music wire springs are not recommended for applications wherein the temperature exceeds 250°F. Corrosion-resisting steel springs are not recommended for applications wherein the temperature exceeds 500°F.
 - (6) IN THE EVENT OF A CONFLICT BETWEEN THE TEXT OF THIS STANDARD AND THE REFERENCES CITED HEREIN, THE TEXT OF THIS STANDARD SHALL TAKE PRECEDENCE.
 - (7) REFERENCED GOVERNMENT (OR NON-GOVERNMENT) DOCUMENTS OF THE ISSUE LISTED IN THAT ISSUE OF THE DEPARTMENT OF DEFENSE INDEX OF SPECIFICATIONS AND STANDARDS (DODISS) SPECIFIED IN THE SOLICITATION, FORM A PART OF THIS STANDARD TO THE EXTENT SPECIFIED HEREIN.

TABLE I - CORRECTION FACTORS FOR STRESS RANGE, LIFE CYCLES AND SPRING MATERIAL

MATERIAL	P ₂ - P ₁	CYCLES				
		5,000	10,000	50,000	100,000	Infinite
MUSIC WIRE	.25	1.28	1.23	1.11	1.06	.95
	.50	1.23	1.16	1.00	.93	.76
	.75	1.21	1.12	.93	.84	.65
	1.00	1.17	1.08	.86	.77	.55
CORROSION-RESISTANT STEEL	.25	.92	.90	.83	.81	.77
	.50	.88	.84	.76	.72	.63
	.75	.85	.80	.68	.63	.51
	1.00	.83	.76	.61	.55	.41

AS24586

TABLE II - DIMENSIONS AND CHARACTERISTICS

Steel				O.D. Outside Dia.	d Wire Dia.	L Free Length	N Active Coils	f Defl. Per Coil	P 2/ Load Lb Max	T Initial Tension Lbs	L ₁ 3/ Ext Max	R 2/ Spring Rate Lb/in.
Uncoated	Cadmium Plated	Zinc Coated	Corrosion Resisting									
Dash No.	Dash No.	Dash No.	Dash No.									
1	501		C1	.120	.016	1.000	50.5	.0161	1.6	.2	1.81	1.74
2	502		C2			1.125	58.5				2.07	1.49
3	503		C3			1.250	66.0				2.31	1.32
4	504		C4			1.375	74.0				2.57	1.18
5	505		C5			1.500	82.0				2.82	1.06
6	506	1006	C6		1.000	45.5	1.60	3.33				
7	507	1007	C7		1.125	52.0	1.81	2.89				
8	508	1008	C8		1.250	59.0	2.03	2.55				
9	509	1009	C9		1.375	66.5	2.25	2.28				
10	510	1010	C10		1.500	73.0	2.47	2.06				
11	511	1011	C11		1.625	80.0	2.69	1.88				
12	512	1012	C12		1.750	87.0	2.90	1.72				
13	513	1013	C13		1.875	94.0	3.12	1.60				
14	514	1014	C14		2.000	101.0	3.34	1.49				
15	515		C15		1.000	41.0	1.45	6.00				
16	516		C16	1.125	47.0	1.64	4.24					
17	517		C17	1.250	53.5	1.84	4.58					
18	518		C18	1.375	60.0	2.04	4.06					
19	519		C19	1.500	66.0	2.23	3.70					
20	520		C20	1.625	72.5	2.43	3.35					
21	521		C21	1.750	78.5	2.62	3.10					
22	522		C22	1.875	84.5	2.81	2.89					
23	523		C23	2.000	91.0	3.01	2.67					
24	524		C24	1.000	37.5	1.34	10.38					
25	525		C25	1.125	43.0	1.51	9.04					
26	526		C26	1.250	49.0	1.69	7.94					
27	527		C27	1.375	54.5	1.86	7.20					
28	528		C28	1.500	60.0	2.04	6.48					
29	529		C29	1.625	66.0	2.22	5.89					
30	530		C30	1.750	71.5	2.39	5.48					
31	531		C31	1.875	77.0	2.57	5.05					
32	532		C32	2.000	83.0	2.75	4.68					
33	533		C33	2.125	88.5	2.92	4.42					
34	534		C34	2.250	94.5	3.10	4.12					
35	535		C35	2.375	100.0	3.28	3.89					
36	536		C36	2.500	106.5	3.45	3.67					
37	537	1037	C37	1.000	23.0	1.97	3.08					
38	538	1038	C38	1.125	28.0	2.31	2.53					
39	539	1039	C39	1.250	32.5	2.64	2.18					
40	540	1040	C40	1.375	37.5	2.96	1.89					
41	541	1041	C41	.240	.026	1.500	42.0	.0424	3.3	.3	3.28	1.69
42	542	1042	C42	1.625	47.0	3.62	1.51					
43	543	1043	C43	1.750	52.0	3.95	1.36					
44	544	1044	C44	1.875	56.5	4.27	1.25					
45	545	1045	C45	2.000	61.5	4.60	1.15					

2/ - See Note (2). 3/ - See Note (3).

AS24586

TABLE II - Continued

Steel				O.D. Outside Dia.	d Wire Dia.	L Free Length	N Active Coils	f Defl. Per Coil	P 2/ Load Lb Max	T Initial Tension Lbs	L ₁ 3/ Ext Max	R 2/ Spring Rate Lb/in.
Uncoated	Cadmium Plated	Zinc Coated	Corrosion Resisting									
Dash No.	Dash No.	Dash No.	Dash No.									
46	546	1046	C46			1.000	20.0				1.64	7.54
47	547	1047	C47			1.125	24.0				1.89	6.52
48	548	1048	C48			1.250	28.0				2.14	5.39
49	549	1049	C49			1.375	31.0				2.36	4.87
50	550	1050	C50			1.500	36.0				2.64	4.20
51	551	1051	C51			1.625	40.0				2.89	3.77
52	552	1052	C52		.031	1.750	44.0	.0318	5.3	.5	3.15	3.43
53	553	1053	C53			1.875	47.0				3.37	3.21
54	554	1054	C54			2.000	52.0				3.65	2.90
55	555	1055	C55			2.125	56.0				3.91	2.70
56	556	1056	C56			2.250	60.0				4.16	2.52
57	557	1057	C57			2.375	64.0				4.41	2.36
58	558	1058	C58			2.500	68.0				4.66	2.22
59	559		C59			1.000	17.0				1.40	19.80
60	560		C60			1.125	20.5				1.61	16.42
61	561		C61			1.250	24.0				1.81	14.01
62	562		C62			1.375	27.0				2.01	12.46
63	563		C63			1.500	30.5				2.20	11.20
64	564		C64			1.625	34.0				2.42	9.89
65	565		C65			1.750	37.5				2.63	8.97
66	566		C66		.037	1.875	40.5	.0235	8.7	.8	2.83	8.31
67	567		C67			2.000	44.0				3.04	7.64
68	568		C68			2.125	47.5				3.24	7.08
69	569		C69	.240		2.250	51.0				3.45	6.59
70	570		C70			2.375	54.5				3.59	6.16
71	571		C71			2.500	57.5				3.85	5.85
72	572		C72			2.750	64.5				4.27	5.21
73	573		C73			3.000	71.0				4.67	4.74
74	574	1074	C74			1.000	15.5				1.30	34.55
75	575	1075	C75			1.125	18.5				1.48	28.97
76	576	1076	C76			1.250	21.5				1.67	24.94
77	577	1077	C77			1.375	25.0				1.86	21.44
78	578	1078	C78			1.500	28.0				2.04	19.15
79	579	1079	C79			1.625	31.0				2.23	17.30
80	580	1080	C80			1.750	34.0				2.41	15.76
81	581	1081	C81			1.875	37.0				2.59	14.48
82	582	1082	C82		.041	2.000	40.0	.0194	11.4	1.0	2.78	13.40
83	583	1083	C83			2.125	43.0				2.96	12.47
84	584	1084	C84			2.250	46.0				3.14	11.66
85	585	1085	C85			2.375	49.0				3.33	10.94
86	586	1086	C86			2.500	52.0				3.51	10.31
87	587	1087	C87			2.750	58.5				3.88	9.16
88	588	1088	C88			3.000	64.5				4.25	8.31
89	589	1089	C89			3.250	70.5				4.62	7.60
90	590	1090	C90			3.500	76.5				4.98	7.01

2/ - See Note (2). 3/ - See Note (3).

AS24586

TABLE II - Continued

Steel				O.D. Outside Dia.	d Wire Dia.	L Free Length	N Active Coils	f Defl. Per Coil	P 2/ Load Lb Max	T Initial Tension Lbs	L ₁ 3/ Ext Max	R 2/ Spring Rate Lb/in.
Uncoated	Cadmium Plated	Zinc Coated	Corrosion Resisting									
Dash No.	Dash No.	Dash No.	Dash No.									
91	591	1091	C91	.360	.031	1.000	12.0	.085	3.6	.3	2.02	3.24
92	592	1092	C92			1.125	16.0				2.48	2.43
93	593	1093	C93			1.250	20.0				2.95	1.94
94	594	1094	C94			1.375	24.0				3.41	1.62
95	595	1095	C95			1.500	28.0				3.81	1.43
96	596		C96		1.000	10.5	1.68	7.92				
97	597		C97		1.125	14.0	2.04	5.93				
98	598		C98		1.250	17.5	2.39	4.75				
99	599		C99		1.375	20.5	2.71	4.05				
100	600		C100		1.500	24.0	3.06	3.46				
101	601		C101	.037	1.625	27.5	.065	5.9	.5	3.41	3.02	
102	602		C102		1.750	31.0				3.77	2.67	
103	603		C103		1.875	34.0				4.09	2.44	
104	604		C104		2.000	37.5				4.44	2.22	
105	605		C105		2.125	41.0				4.79	2.03	
106	606		C106	2.250	44.5	5.14	1.87					
107	607		C107	2.375	47.5	5.46	1.75					
108	608		C108	2.500	51.0	5.81	1.63					
109	609	1109	C109	.041	1.000	10.0	.0555	7.9	.7	1.55	12.97	
110	610	1110	C110		1.125	13.0				1.85	9.99	
111	611	1111	C111	.041	1.250	16.0	.0555	7.9	.7	2.14	8.11	
112	612	1112	C112		1.375	19.0				2.43	6.83	
113	613	1113	C113		1.500	22.0				2.72	5.90	
114	614	1114	C114		1.625	25.0				3.01	5.19	
115	615	1115	C115		1.750	28.0				3.30	4.63	
116	616	1116	C116		1.875	31.0				3.60	4.19	
117	617	1117	C117		2.000	34.0				3.89	3.82	
118	618	1118	C118		2.125	37.0				4.18	3.51	
119	619	1119	C119		2.250	40.5				4.50	3.20	
120	620	1120	C120		2.375	43.5				4.79	2.98	
121	621	1121	C121	.045	2.500	46.5	.0472	10.2	.9	5.08	2.79	
122	722	1122	C122		1.000	9.0				1.43	21.88	
123	623	1123	C123		1.125	12.0				1.69	16.43	
124	624	1124	C124		1.250	14.5				1.93	13.60	
125	625	1125	C125		1.375	17.5				2.20	11.26	
126	626	1126	C126	1.500	20.5	2.47	9.61					
127	627	1127	C127	1.625	23.0	2.71	8.56					
128	628	1128	C128	1.750	26.0	2.98	7.58					
129	629	1129	C129	1.875	28.5	3.22	6.91					
130	630	1130	C130	2.000	31.5	3.49	6.25					
131	631	1131	C131	.045	2.125	34.0	.0472	10.2	.9	3.77	5.79	
132	632	1132	C132		2.250	37.0				4.00	5.33	
133	633	1133	C133		2.375	40.0				4.26	4.92	
134	634	1134	C134		2.500	42.5				4.51	4.64	
135	635	1135	C135		2.750	48.0				5.02	4.10	

2/ - See Note (2). 3/ - See Note (3).

AS24586

TABLE II - Continued

Steel				O.D. Outside Dia.	d Wire Dia.	L Free Length	N Active Coils	f Defl. Per Coil	P 2/ Load Lb Max	T Initial Tension Lbs	L ₁ 3/ Ext Max	R 2/ Spring Rate Lb/in.	
Uncoated	Cadmium Plated	Zinc Coated	Corrosion Resisting										
Dash No.	Dash No.	Dash No.	Dash No.										
136	636	1136	C136	.360	.045	3.000	53.5	.0472	10.2	.9	5.53	3.68	
137	637		C137			1.125	10.5				1.49	45.98	
138	638		C138			1.250	12.5				1.66	38.65	
139	639		C139			1.375	15.0				1.87	32.19	
140	640		C140			1.500	17.0				2.06	28.42	
141	641		C141		1.625	19.5	2.27	24.81					
142	642		C142		1.750	21.5	2.46	22.47					
143	643		C143		1.875	24.0	2.67	20.15					
144	644		C144		2.000	26.5	2.87	18.24					
145	645		C145		2.125	28.5	3.07	16.97					
146	646		C146		.500	.055	2.250	31.0	.0331	17.6	1.6	3.28	15.59
147	647		C147				2.375	33.0				3.47	14.65
148	648		C148				2.500	35.5				3.68	13.62
149	649		C149				2.750	40.0				4.07	12.08
150	650		C150				3.000	44.5				4.47	10.86
151	651		C151	3.250		49.0	4.87	9.86					
152	652		C152	3.500		53.5	5.27	9.03					
153	653		C153	3.750		58.0	5.67	8.33					
154	654		C154	4.000		62.5	6.10	7.73					
155	655		C155	4.250		67.0	6.47	7.21					
156	656	1157	C156	4.500		71.5	6.81	6.76					
157	657		C157	1.250		10.0	2.65	2.85					
158	658		1158	C158		1.375	13.0	3.20	2.19				
159	659		1159	C159		1.500	16.5	3.81	1.73				
160	660		1160	C160		1.625	20.0	4.43	1.43				
161	661	1161	C161	1.750	23.0	4.98	1.24						
162	662		C162	1.250	9.0	2.34	4.87						
163	663		C163	1.375	12.0	2.83	3.66						
164	664		C164	1.500	15.0	3.32	2.92						
165	665		C165	1.625	18.0	3.80	2.43						
166	666		C166	.500	.041	1.750	21.0	.121	5.8	.5	4.29	2.09	
167	667		C167			1.875	24.5				4.84	1.79	
168	668		C168			2.000	27.5				5.33	1.59	
169	669		C169			2.125	30.5				5.82	1.44	
170	670		C170			2.250	33.5				6.30	1.31	
171	671	1171	C171		1.375	11.5	2.58	5.66					
172	672		1172		C172	1.500	14.0	2.94	4.65				
173	673		1173		C173	1.625	17.0	3.40	3.83				
174	674		1174		C174	1.750	19.5	3.79	3.34				
175	675		1175		C175	1.875	22.5	4.23	2.89				
176	676	1176	C176		2.000	25.0	4.61	2.60					
177	677		1177		C177	2.125	28.0	5.05	2.32				
178	678		1178		C178	2.250	31.0	5.49	2.10				
179	679		C179		1.375	10.0	2.14	15.64					
180	680		C180		1.500	12.0	2.41	13.03					

2/ - See Note (2). 3/ - See Note (3).

AS24586

TABLE II - Continued

Steel				O.D. Outside Dia.	d Wire Dia.	L Free Length	N Active Coils	f Defl. Per Coil	P 2/ Load Lb Max	T Initial Tension Lbs	L ₁ 3/ Ext Max	R 2/ Spring Rate Lb/in.
Uncoated	Cadmium Plated	Zinc Coated	Corrosion Resisting									
Dash No.	Dash No.	Dash No.	Dash No.									
181	681		C181			1.625	14.5				2.73	10.79
182	682		C182			1.750	16.5				3.01	9.00
183	683		C183			1.875	19.0				3.92	8.23
184	684		C184			2.000	21.0				3.60	7.45
185	685		C185			2.125	23.5				3.91	6.66
186	686		C186			2.250	25.5				4.29	6.13
187	687		C187			2.375	28.0				4.51	5.58
188	688		C188			2.500	30.5				4.82	5.13
189	689		C189		.055	2.750	35.0	.0761	13.1	1.2	5.41	4.47
190	690		C190			3.000	39.5				6.01	3.96
191	691		C191			3.250	43.0				6.52	3.64
192	692		C192			3.500	48.5				7.19	3.22
193	693		C193			3.750	54.0				7.86	2.90
194	694		C194			4.000	57.5				8.38	2.72
195	695		C195			4.250	62.0				8.97	2.52
196	696		C196			4.500	66.5				9.56	2.35
197	697	1197	C197			1.375	9.0				1.92	31.26
198	698	1198	C198			1.500	11.0				2.17	25.56
199	699	1199	C199			1.625	13.0				2.42	21.65
200	700	1200	C200	.500		1.750	15.0				2.66	18.75
201	701	1201	C201			1.875	17.0				2.91	16.54
202	702	1202	C202			2.000	19.0				3.16	14.81
203	703	1203	C203			2.125	21.0				3.40	13.39
204	704	1204	C204			2.250	23.0				3.65	12.23
205	705	1205	C205			2.375	25.0				3.90	11.25
206	706	1206	C206		.063	2.500	27.0	.0608	18.8	1.7	4.12	10.41
207	707	1207	C207			2.750	30.5				4.60	9.22
208	708	1208	C208			3.000	34.5				5.10	8.15
209	709	1209	C209			3.250	38.5				5.59	7.30
210	710	1210	C210			3.500	42.5				6.08	6.62
211	711	1211	C211			3.750	46.5				6.58	6.05
212	712	1212	C212			4.000	50.5				7.07	5.57
213	713	1213	C213			4.250	54.5				7.56	5.16
214	714	1214	C214			4.500	58.5				8.06	4.81
215	715	1215	C215			4.750	62.5				8.55	4.50
216	716	1216	C216			5.000	66.5				9.04	4.23
217	717		C217			2.000	15.5				4.20	4.18
218	718		C218			2.125	18.0				4.68	3.60
219	719		C219			2.250	20.0				5.13	3.24
220	720		C220			2.375	22.5				5.57	2.88
221	721		C221	.650	.055	2.500	24.5	.142	10.1	.9	6.98	2.64
222	722		C222			2.750	29.5				6.94	2.20
223	723		C223			3.000	34.0				7.83	1.90
224	724		C224			3.250	38.5				8.72	1.68
225	725		C225			3.500	43.0				9.61	1.51

2/ - See Note (2). 3/ - See Note (3).

AS24586

TABLE II - Continued

Steel				O.D. Outside Dia.	d Wire Dia.	L Free Length	N Active Coils	f Defl. Per Coil	P 2/ Load Lb Max	T Initial Tension Lbs	L ₁ 3/ Ext Max	R 2/ Spring Rate Lb/in.			
Uncoated	Cadmium Plated	Zinc Coated	Corrosion Resisting												
Dash No.	Dash No.	Dash No.	Dash No.												
226	726		C226	.650	.055	3.750	47.5	.142	10.1	.9	10.50	1.36			
227	727		C227			4.000	52.0						11.38	1.25	
228	728	1228	C228			2.000	14.0						3.61	8.32	
229	729	1229	C229			2.125	16.0						3.97	7.28	
230	730	1230	C230			2.250	18.0						4.32	6.47	
231	731	1231	C231		.063	.650	2.375	20.0	.115	14.8	1.4	6.45	3.88		
232	732	1232	C232				2.500	22.0						5.03	5.30
233	733	1233	C233				2.750	26.0						5.74	4.48
234	734	1234	C234				3.000	30.0						6.45	3.88
235	735	1235	C235				3.250	34.0						7.16	3.43
236	736	1236	C236	.750		.055	3.500	38.0	.197	8.8	.8	7.77	1.59		
237	737	1237	C237				3.750	42.0						8.58	2.77
238	738	1238	C238				4.000	46.0						9.29	2.53
239	739	1239	C239				4.250	50.0						10.00	2.33
240	740	1240	C240				4.500	54.0						10.71	2.16
241	741		C241		.063	.750	2.000	12.0	.161	12.8	1.2	7.35	2.67		
242	742		C242				2.125	14.5						8.16	2.36
243	743		C243				2.250	16.5						9.05	2.09
244	744		C244				2.375	19.0						9.95	1.87
245	745		C245				2.500	21.0						10.84	1.70
246	746		C246	.075		.750	2.750	25.5	.1218	20.7	1.9	3.63	13.42		
247	747		C247				3.000	30.0						3.83	11.88
248	748		C248				3.250	35.0						4.14	10.65
249	749		C249				3.500	39.5						4.51	9.35
250	750	1250	C250				2.000	11.0						3.16	16.25
251	751	1251	C251		.063	.750	2.125	13.0	.161	12.8	1.2	7.35	2.67		
252	752	1252	C252				2.250	15.0						8.16	2.36
253	753	1253	C253				2.375	17.0						9.05	2.09
254	754	1254	C254				2.500	19.0						9.95	1.87
255	755	1255	C255				2.750	22.0						10.84	1.70
256	756	1256	C256	.075		.750	3.000	27.0	.161	12.8	1.2	7.35	2.67		
257	757	1257	C257				3.250	30.5						8.16	2.36
258	758	1258	C258				3.500	34.5						9.05	2.09
259	759	1259	C259				3.750	38.5						9.95	1.87
260	760	1260	C260				4.000	42.5						10.84	1.70
261	761	1261	0261		.075	.750	4.250	46.5	.1218	20.7	1.9	3.63	13.42		
262	762	1262	0262				4.500	50.5						3.83	11.88
263	763	1263	C263				4.750	54.5						4.14	10.65
264	764	1264	C264				5.000	58.5						4.51	9.35
265	765	1265	C265				2.000	9.5						3.16	16.25
266	766	1266	C266	.075		.750	2.125	11.5	.1218	20.7	1.9	3.63	13.42		
267	767	1267	C267				2.250	13.0						3.83	11.88
268	768	1268	C268				2.375	14.5						4.14	10.65
269	769	1269	C269				2.500	16.5						4.51	9.35
270	770	1270	C270				2.750	19.5						5.13	7.92

2/ - See Note (2). 3/ - See Note (3).

AS24586

TABLE II - Continued

Steel				O.D.	d	L	N	f	P 2/	T	L ₁ 3/	R 2/
Uncoated	Cadmium Plated	Zinc Coated	Corrosion Resisting	Outside Dia.	Wire Dia.	Free Length	Active Coils	Defl. Per Coil	Load Lb Max	Initial Tension Lbs	Ext Max	Spring Rate Lb/in.
Dash No.	Dash No.	Dash No.	Dash No.									
271	771	1271	C271	.750	.075	3.000	23.0	.1218	20.7	1.9	5.80	6.71
272	772	1272	C272			3.250	26.5				6.48	5.82
273	773	1273	C273			3.500	29.5				7.09	5.23
274	774	1274	C274			3.750	33.0				7.77	4.68
275	775	1275	C275			4.000	36.5				8.45	4.23
276	776	1276	C276			4.250	39.5				9.06	3.91
277	777	1277	C277			4.500	43.0				9.74	3.59
278	778	1278	C278			4.750	46.5				10.41	3.32
279	779	1279	C279			5.000	49.5				11.03	3.12
280	780		C280			2.000	8.5				4.22	3.20
281	781		C281	.055		2.125	10.5	.2613	7.8	.7	4.87	2.59
282	782		C282			2.250	13.0				5.65	2.09
283	783		C283			2.375	15.0				6.29	1.81
284	784		C284			2.500	17.5				7.07	1.55
285	785		C285			2.750	22.0				8.50	1.24
286	786		C286	.063		2.125	9.5	.2286	11.3	1.0	4.30	4.74
287	787		C287			2.250	11.5				4.88	3.92
288	788		C288			2.375	13.5				5.46	3.34
289	789		C289			2.500	15.5				6.04	2.91
290	790		C290			2.750	19.5				7.21	2.31
291	791		C291			3.000	23.5				8.37	1.92
292	792		C292	3.250	27.5	9.54	1.64					
293	793		C293	3.500	31.5	10.70	1.43					
294	794		C294	.075		2.250	10.5	.164	18.4	1.7	3.97	9.70
295	795		C295			2.375	12.0				4.34	8.49
296	796		C296			2.500	13.5				4.71	7.54
297	797		C297			2.750	17.0				5.54	5.99
298	798		C298			3.000	20.5				6.36	4.97
299	799		C299			3.250	23.5				7.10	4.33
300	800		C300			3.500	27.0				7.93	3.77
301	801		C301			3.750	30.5				8.75	3.34
302	802		C302			4.000	33.5				9.49	3.04
303	803		C303			4.250	37.0				10.32	2.75
304	804		C304	4.500	40.5	11.14	2.51					
305	805		C305	4.750	43.5	11.88	2.34					
306	806		C306	.085		5.000	47.0	.1344	25.9	2.4	12.71	2.17
307	807		C307			2.250	9.5				3.52	19.15
308	808		C308			2.375	11.0				3.85	15.90
309	809		C309			2.500	12.5				4.18	13.99
310	810		C310			2.750	15.5				4.83	11.28
311	811		C311	3.000	18.5	5.49	9.45					
312	812		C312	3.250	21.5	6.14	8.13					
313	813		C313	3.500	24.0	6.73	7.28					
314	814		C314	3.750	27.0	7.38	6.48					
315	815		C315	4.000	30.0	8.03	5.83					

2/ - See Note (2). 3/ - See Note (3).

AS24586

TABLE II - Continued

Steel				O.D.	d	L	N	f	P 2/	T	L ₁ 3/	R 2/
Uncoated	Cadmium Plated	Zinc Coated	Corrosion Resisting	Outside Dia.	Wire Dia.	Free Length	Active Coils	Defl. Per Coil	Load Lb Max	Initial Tension Lbs	Ext Max	Spring Rate Lb/in.
Dash No.	Dash No.	Dash No.	Dash No.									
316	816		C316	.850	.085	4.250	33.0	.1344	25.9	2.4	8.68	5.30
317	817		C317			4.500	36.0				9.34	4.86
318	818		C318			4.750	39.0				9.99	4.48
319	819		C319			5.000	42.0				10.64	4.16
320	820	1320	C320			2.500	11.0				5.91	2.58
321	821	1321	C321	1.000	0.63	2.750	15.0	.31	9.7	.9	7.40	1.89
322	822	1322	C322			3.000	19.0				8.89	1.49
323	823	1323	C323			3.250	23.0				10.38	1.23
324	824	1324	C324			2.500	9.5				4.77	6.31
325	825	1325	C325			2.750	13.0				5.85	4.61
326	826	1326	C326	.075		3.000	16.5	.2387	15.7	1.4	6.94	3.63
327	827	1327	C327			3.250	19.5				7.91	3.07
328	828	1328	C328			3.500	23.0				8.99	2.60
329	829	1329	C329			3.750	26.5				10.07	2.26
330	830	1330	C330			4.000	29.5				11.04	2.03
331	831	1331	C331			4.250	33.0				12.13	1.82
332	832	1332	C332			4.500	36.5				13.21	1.64
333	833	1333	C333			4.750	39.5				14.18	1.52
334	834	1334	C334			5.000	43.0				15.26	1.39
335	835		C335			2.750	12.0				5.12	8.53
336	836		C336	.085		3.000	15.0	.1974	22.2	2.0	5.96	6.82
337	837		C337			3.250	18.0				6.80	5.69
338	838		C338			3.500	20.5				7.55	4.99
339	839		C339			3.750	23.5				8.39	4.35
340	840		C340			4.000	26.5				9.23	3.86
341	841		C341			4.250	29.5				10.07	3.47
342	842		C342			4.500	32.5				10.92	3.15
343	843		C343			4.750	35.5				11.76	2.88
344	844		C344			5.000	38.5				12.60	2.66
345	845	1345	C345			2.750	11.0				4.57	14.98
346	846	1346	C346	.095		3.000	13.5	.1657	30.0	2.7	5.24	12.20
347	847	1347	C347			3.250	16.0				5.90	10.30
348	848	1348	C348			3.500	19.0				6.65	8.67
349	849	1349	C349			3.750	21.5				7.31	7.66
350	850	1350	C350			4.000	24.0				7.98	6.86
351	851	1351	C351			4.250	26.5				8.64	6.22
352	852	1352	C352			4.500	29.5				9.39	5.59
353	853	1353	C353			4.750	32.0				10.05	5.15
354	854	1354	C354			5.000	34.5				10.72	4.78

2/ - See Note (2). 3/ - See Note (3).